

Exponential Enclosure Techniques for the Computation of Guaranteed State Enclosures in VALENCIA-IVP

SCAN 2012: 15th GAMM-IMACS Intl. Symposium on Scientific
Computing, Computer Arithmetic and Verified Numerical
Computations

Novosibirsk, Russia

September 24, 2012

Andreas Rauh¹, Ekaterina Auer², Ramona Westphal¹, Harald Aschemann¹

¹Chair of Mechatronics, University of Rostock, Germany

²Faculty of Engineering, INKO, University of Duisburg-Essen, Germany

Overview

- Initial value problems for sets of ordinary differential equations (ODEs)
 - Uncertainty in initial conditions
 - Uncertainty in parameters
- Basic procedures implemented in VALENCIA-IVP
 - Iterative computation of additive error bounds
 - Exponential state enclosures
 - Preconditioning strategies
- Exponential state enclosure techniques
 - Linear dynamic systems with real eigenvalues
 - Linear dynamic systems with complex eigenvalues
- Further extensions
 - Automatic test for cooperativity
 - Initial value problems for sets of differential-algebraic equations (DAEs)
 - (Algebraic) Consistency test

Initial Value Problems with Interval Uncertainties (1)

- Nonlinear continuous-time state equations

$$\dot{\mathbf{x}}_s(t) = \mathbf{f}_s(\mathbf{x}_s(t), \mathbf{p}(t), t)$$

with the initial states $\mathbf{x}_s(0) = \mathbf{x}_s^0$

$\mathbf{x}_s(t)$ state vector

$\mathbf{p}(t)$ parameter vector

Initial Value Problems with Interval Uncertainties (1)

- Nonlinear continuous-time state equations

$$\dot{\mathbf{x}}_s(t) = \mathbf{f}_s(\mathbf{x}_s(t), \mathbf{p}(t), t)$$

with the initial states $\mathbf{x}_s(0) = \mathbf{x}_s^0$

$\mathbf{x}_s(t)$ state vector

$\mathbf{p}(t)$ parameter vector

- Interval uncertainty in initial conditions and parameters

$$[\mathbf{x}_s^0] := [\underline{\mathbf{x}}_s^0 ; \overline{\mathbf{x}}_s^0]$$

$$[\mathbf{p}(t)] := [\underline{\mathbf{p}}(t) ; \overline{\mathbf{p}}(t)]$$

with a dynamical model of time-varying parameters

$$\dot{\mathbf{p}}(t) = \Delta \mathbf{p}(t)$$

and the variation rates

$$\Delta \mathbf{p}(t) \in [\Delta \mathbf{p}(t)] := [\underline{\Delta \mathbf{p}}(t) ; \overline{\Delta \mathbf{p}}(t)]$$

Initial Value Problems with Interval Uncertainties (2)

- Dynamical system model (set of ordinary differential equations)

$$\dot{\mathbf{x}}(t) = \mathbf{f}(\mathbf{x}(t), t) := \begin{bmatrix} \mathbf{f}_s(\mathbf{x}_s(t), \mathbf{p}(t), t) \\ \Delta \mathbf{p}(t) \end{bmatrix}$$

after definition of the extended state vector

$$\mathbf{x}(t) := \begin{bmatrix} \mathbf{x}_s(t) \\ \mathbf{p}(t) \end{bmatrix}$$

Initial Value Problems with Interval Uncertainties (2)

- Dynamical system model (set of ordinary differential equations)

$$\dot{\mathbf{x}}(t) = \mathbf{f}(\mathbf{x}(t), t) := \begin{bmatrix} \mathbf{f}_s(\mathbf{x}_s(t), \mathbf{p}(t), t) \\ \Delta \mathbf{p}(t) \end{bmatrix}$$

after definition of the extended state vector

$$\mathbf{x}(t) := \begin{bmatrix} \mathbf{x}_s(t) \\ \mathbf{p}(t) \end{bmatrix}$$

Which states can be reached in a given finite time horizon under consideration of the uncertainty in initial states and system parameters?

⇒ Computation of an interval enclosure $[\mathbf{x}_{encl}(t)]$ of all reachable states for each point of time $t \geq 0$

VALENCIA-IVP — VALidation of state ENCllosures using Interval Arithmetic for Initial Value Problems (1)

- Assumption of time-varying state enclosure without need for series expansion

$$\underbrace{[\mathbf{x}_{encl}(t)]}_{\text{verified state enclosure}} := \underbrace{\mathbf{x}_{app}(t)}_{\text{non-verified approximation}} + \underbrace{[\mathbf{R}(t)]}_{\text{error bounds}}$$

- Selected references:**

E. Auer, A. Rauh, E. P. Hofer, and W. Luther, *Validated Modeling of Mechanical Systems with SMARTMOBILE: Improvement of Performance by VALENCIA-IVP*, In Proc. of Dagstuhl Seminar 06021: *Reliable Implementation of Real Number Algorithms: Theory and Practice*, volume 5045 of Lecture Notes in Computer Science, Springer-Verlag, pp. 1–28, 2008.

A. Rauh, E. Auer: *Verified Simulation of ODEs and DAEs in VALENCIA-IVP*, Special Issue of Reliable Computing, 13th GAMM-IMACS International Symposium on Scientific Computing, Computer Arithmetic, and Validated Numerics SCAN2008, El Paso, USA, 2008. *Reliable Computing*, Vol. 15, No. 4, pp. 370-381, 2011.

VALENCIA-IVP — VALIDation of state ENClosures using Interval Arithmetic for Initial Value Problems (2)

- Assumption of time-varying state enclosure

$$\underbrace{[\mathbf{x}_{encl}(t)]}_{\text{verified state enclosure}} := \underbrace{\mathbf{x}_{app}(t)}_{\text{non-verified approximation}} + \underbrace{[\mathbf{R}(t)]}_{\text{error bounds}}$$

- Iteration formula

$$\begin{aligned}
 [\dot{\mathbf{R}}^{(\kappa+1)}(t)] &= -\dot{\mathbf{x}}_{app}(t) + \mathbf{f}\left([\mathbf{x}_{encl}^{(\kappa)}(t)], t\right) \\
 &= -\dot{\mathbf{x}}_{app}(t) + \mathbf{f}\left(\mathbf{x}_{app}(t) + [\mathbf{R}^{(\kappa)}(t)], t\right) =: \mathbf{r}\left([R^{(\kappa)}(t)], t\right)
 \end{aligned}$$

- Convergence for $[\dot{\mathbf{R}}^{(\kappa+1)}(t)] \subseteq [\dot{\mathbf{R}}^{(\kappa)}(t)]$

$$\implies [\mathbf{R}^{(\kappa+1)}(t)] \subseteq [\mathbf{R}^{(\kappa+1)}(0)] + t \cdot \mathbf{r}\left([\mathbf{R}^{(\kappa)}([0; t])], [0; t]\right), 0 \leq t \leq T$$

VALENCIA-IVP — Exponential State Enclosures (1)

Goal: Prevent growth of interval diameters especially in simulations of asymptotically stable systems

Idea: Use of exponential state enclosures

$$[\mathbf{x}_{encl}(t)] := \exp([\Lambda] \cdot t) \cdot [\mathbf{x}_{encl}(0)] \quad \text{with} \quad [\Lambda] := \text{diag} \{[\lambda_i]\} \quad , \quad i = 1, \dots, n$$

Iteration formula for $[\Lambda_i]$ in the case of convergence, i.e., $[\lambda_i^{(\kappa+1)}] \subseteq [\lambda_i^{(\kappa)}]$:

$$[\lambda_i^{(\kappa+1)}] := \frac{f_i(\exp([\Lambda^{(\kappa)}] \cdot [0; T]) \cdot [\mathbf{x}_{encl}(0)], [0; T])}{\exp([\lambda_i^{(\kappa)}] \cdot [0; T]) \cdot [\mathbf{x}_{encl,i}(0)]} \quad , \quad i = 1, \dots, n$$

VALENCIA-IVP — Exponential State Enclosures (1)

Goal: Prevent growth of interval diameters especially in simulations of asymptotically stable systems

Idea: Use of exponential state enclosures

$$[\mathbf{x}_{encl}(t)] := \exp([\Lambda] \cdot t) \cdot [\mathbf{x}_{encl}(0)] \quad \text{with} \quad [\Lambda] := \text{diag} \{[\lambda_i]\} \quad , \quad i = 1, \dots, n$$

Iteration formula for $[\Lambda_i]$ in the case of convergence, i.e., $[\lambda_i^{(\kappa+1)}] \subseteq [\lambda_i^{(\kappa)}]$:

$$[\lambda_i^{(\kappa+1)}] := \frac{f_i(\exp([\Lambda^{(\kappa)}] \cdot [0; T]) \cdot [\mathbf{x}_{encl}(0)], [0; T])}{\exp([\lambda_i^{(\kappa)}] \cdot [0; T]) \cdot [\mathbf{x}_{encl,i}(0)]} \quad , \quad i = 1, \dots, n$$

Note: Prerequisite for admissibility of differentiation w.r.t. time: guaranteed enclosure of corresponding variation rates (as for the standard iteration of VALENCIA-IVP). **Additionally**, $0 \notin [\mathbf{x}_{encl,i}([0; T])]$ for **all** $i = 1, \dots, n$

VALENCIA-IVP — Exponential State Enclosures (2)

- Picard iteration

$$\left[\mathbf{B}^{(\kappa+1)} \right] := [\mathbf{x}_0] + [0 ; t] \cdot \mathbf{f} \left(\left[\mathbf{B}^{(\kappa)} \right], [0 ; t] \right)$$

- Evaluation for the exponential state enclosure

$$\begin{aligned} & \exp \left(\left[\Lambda^{(\kappa+1)} \right] \cdot [0 ; T] \right) \cdot [\mathbf{x}_{encl}(0)] \\ &= [\mathbf{x}_0] + [0 ; T] \cdot \mathbf{f} \left(\exp \left(\left[\Lambda^{(\kappa)} \right] \cdot [0 ; T] \right) \cdot [\mathbf{x}_{encl}(0)], [0 ; T] \right) \end{aligned}$$

- Differentiation with respect to time

$$\begin{aligned} & \text{diag} \left\{ \left[\lambda_i^{(\kappa+1)} \right] \right\} \cdot \exp \left(\left[\Lambda^{(\kappa+1)} \right] \cdot [0 ; T] \right) \cdot [\mathbf{x}_{encl}(0)] \\ &= \mathbf{f} \left(\exp \left(\left[\Lambda^{(\kappa)} \right] \cdot [0 ; T] \right) \cdot [\mathbf{x}_{encl}(0)], [0 ; T] \right) \end{aligned}$$

VALENCIA-IVP — Exponential State Enclosures (3)

- In the case of convergence, the following expressions hold:

$$\left[\lambda_i^{(\kappa+1)} \right] \subseteq \left[\lambda_i^{(\kappa)} \right] \quad \text{and} \quad \left[\Lambda^{(\kappa+1)} \right] \subseteq \left[\Lambda^{(\kappa)} \right]$$

- Inclusion monotonicity implies

$$\exp\left(\left[\Lambda^{(\kappa+1)} \right] \cdot [0 ; T]\right) \subseteq \exp\left(\left[\Lambda^{(\kappa)} \right] \cdot [0 ; T]\right)$$

- Substitution on the left-hand side leads to

$$\begin{aligned} & \text{diag} \left\{ \left[\tilde{\lambda}_i^{(\kappa+1)} \right] \right\} \cdot \underbrace{\exp\left(\left[\Lambda^{(\kappa)} \right] \cdot [0 ; T]\right) \cdot [\mathbf{x}_{encl}(0)]}_{\left[\mathbf{x}_{encl}^{(\kappa)}([0 ; T]) \right]} \\ & := \mathbf{f} \left(\exp\left(\left[\Lambda^{(\kappa)} \right] \cdot [0 ; T]\right) \cdot [\mathbf{x}_{encl}(0)], [0 ; T] \right) \end{aligned}$$

VALENCIA-IVP — Exponential State Enclosures (4)

- Substitution on the left-hand side leads to

$$\begin{aligned} \text{diag} \left\{ \left[\tilde{\lambda}_i^{(\kappa+1)} \right] \right\} \cdot \underbrace{\exp \left(\left[\Lambda^{(\kappa)} \right] \cdot [0 ; T] \right) \cdot [\mathbf{x}_{encl} (0)]}_{\left[\mathbf{x}_{encl}^{(\kappa)} ([0 ; T]) \right]} \\ := \mathbf{f} \left(\exp \left(\left[\Lambda^{(\kappa)} \right] \cdot [0 ; T] \right) \cdot [\mathbf{x}_{encl} (0)], [0 ; T] \right) \end{aligned}$$

and therefore

$$\left[\lambda_i^{(\kappa+1)} \right] := \frac{f_i \left(\exp \left(\left[\Lambda^{(\kappa)} \right] \cdot [0 ; T] \right) \cdot [\mathbf{x}_{encl} (0)], [0 ; T] \right)}{\exp \left(\left[\lambda_i^{(\kappa)} \right] \cdot [0 ; T] \right) \cdot [\mathbf{x}_{encl,i} (0)]}, \quad i = 1, \dots, n$$

- Highest efficiency if the state equations are (linear) decoupled and asymptotically stable
- Transformation into Jordan normal form

Preconditioning of State Equations (1)

- Linear systems: Transformation into **real Jordan normal form**

$$\dot{\mathbf{x}}(t) = \mathbf{A}\mathbf{x}(t) \quad \text{with} \quad \mathbf{A} = \begin{bmatrix} \lambda_1 & 0 & \dots & 0 \\ 0 & \lambda_2 & \ddots & \vdots \\ \vdots & \ddots & \ddots & 0 \\ 0 & \dots & 0 & \lambda_n \end{bmatrix}, \quad \mathbf{A} = \begin{bmatrix} \lambda_1 & 1 & 0 & \dots \\ 0 & \lambda_1 & 0 & \dots \\ \vdots & \ddots & \lambda_2 & \dots \\ \dots & & & \dots \end{bmatrix}$$

- Nonlinear systems: Transformation by the matrix of the eigenvectors of the Jacobian evaluated for the interval midpoints of all uncertain variables
 \implies Improvement of the efficiency of the iteration for exponential enclosures
- For non-negligible uncertainty, nonlinear systems, and **not** asymptotically stable dynamics: Combination with consistency test is often inevitable

Preconditioning of State Equations (1)

- Linear systems: Transformation into **real Jordan normal form**

$$\dot{\mathbf{x}}(t) = \mathbf{A}\mathbf{x}(t) \quad \text{with} \quad \mathbf{A} = \begin{bmatrix} \lambda_1 & 0 & \dots & 0 \\ 0 & \lambda_2 & \dots & \vdots \\ \vdots & \dots & \dots & 0 \\ 0 & \dots & 0 & \lambda_n \end{bmatrix}, \quad \mathbf{A} = \begin{bmatrix} \lambda_1 & 1 & 0 & \dots \\ 0 & \lambda_1 & 0 & \dots \\ \vdots & \dots & \lambda_2 & \dots \\ \dots & & & \dots \end{bmatrix}$$

- Nonlinear systems: Transformation by the matrix of the eigenvectors of the Jacobian evaluated for the interval midpoints of all uncertain variables
 \implies Improvement of the efficiency of the iteration for exponential enclosures
- For non-negligible uncertainty, nonlinear systems, and **not** asymptotically stable dynamics: Combination with consistency test is often inevitable
- **New:** Transformation into **complex Jordan normal form** for systems with complex eigenvalues \implies Backward transformation of complex state enclosure

$$\mathbf{A} = \begin{bmatrix} \sigma_1 & \omega_1 \\ -\omega_1 & \sigma_1 \end{bmatrix} \quad \text{vs.} \quad \mathbf{A} = \begin{bmatrix} \sigma_1 + j\omega_1 & 0 \\ 0 & \sigma_1 - j\omega_1 \end{bmatrix}$$

Preconditioning of State Equations (2)

Typical technical applications in control engineering with conjugate complex eigenvalues

- Electric drives (RLC circuits)
- Power trains with elasticities
- Active/ passive oscillation damping (spring-mass-damper systems, quarter vehicle models)

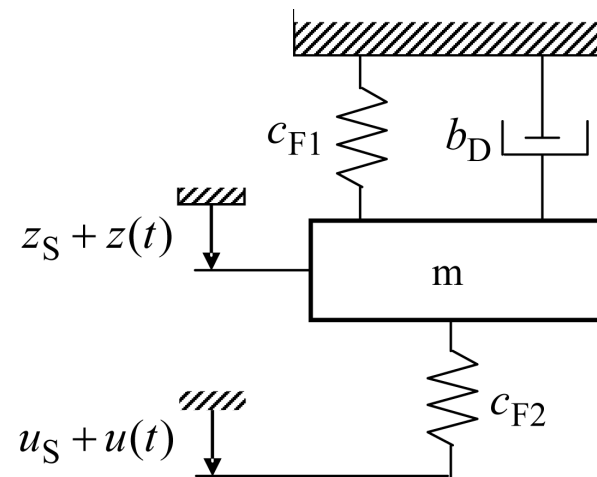

Example 1

- Dynamic system model

$$\dot{\mathbf{x}}(t) = \mathbf{A}\mathbf{x}(t) \quad \text{with} \quad \mathbf{A} = \begin{bmatrix} \sigma_1 & \omega_1 \\ -\omega_1 & \sigma_1 \end{bmatrix}, \quad \sigma_1 = -3, \quad \omega = 1$$

- Initial conditions

$$\mathbf{x}(0) \in \begin{bmatrix} [0.9; 1.1] \\ [0.9; 1.1] \end{bmatrix}$$

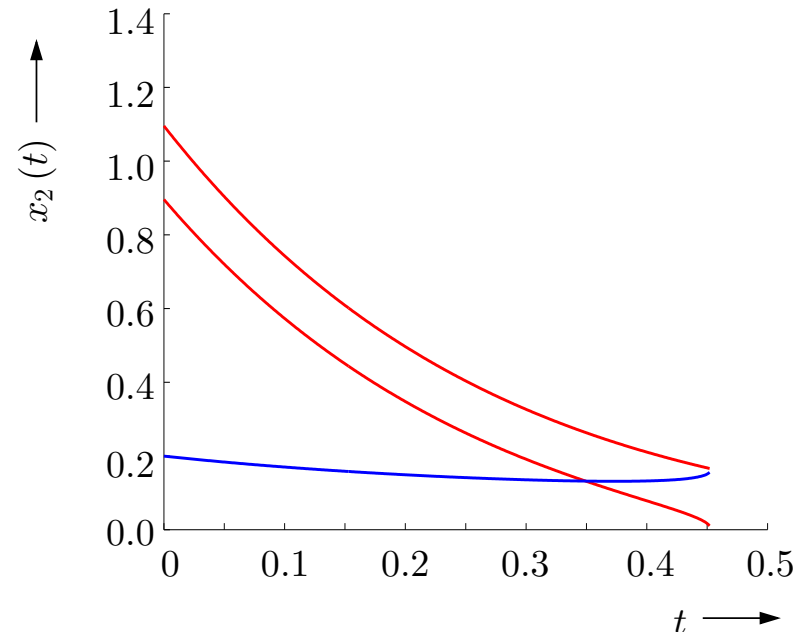
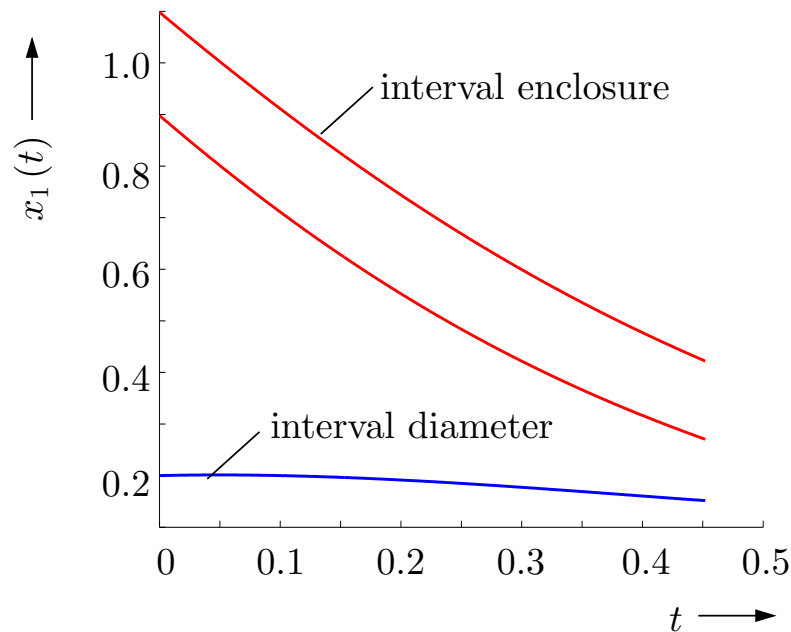

Example 1 (cont'd)

- Dynamic system model

$$\dot{\mathbf{z}}(t) = \tilde{\mathbf{A}}\mathbf{z}(t) \quad \text{with} \quad \tilde{\mathbf{A}} = \begin{bmatrix} \sigma_1 + j\omega_1 & 0 \\ 0 & \sigma_1 - j\omega_1 \end{bmatrix}, \quad \sigma_1 = -3, \quad \omega = 1$$

- Initial conditions (midpoint radius form)

$$\mathbf{z}(0) \in \left[\left\langle \frac{1}{2}\sqrt{2} \cdot (1 - j), \frac{1}{10}\sqrt{2} \right\rangle, \left\langle \frac{1}{2}\sqrt{2} \cdot (1 + j), \frac{1}{10}\sqrt{2} \right\rangle \right]$$

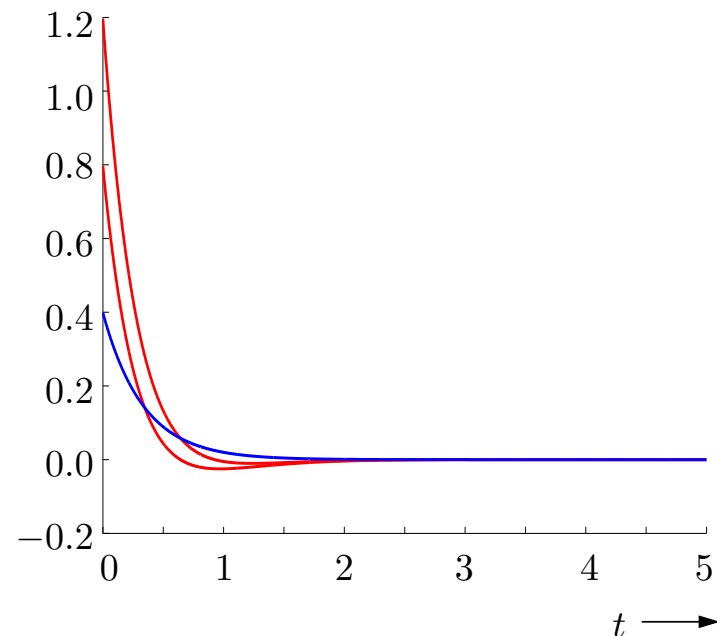
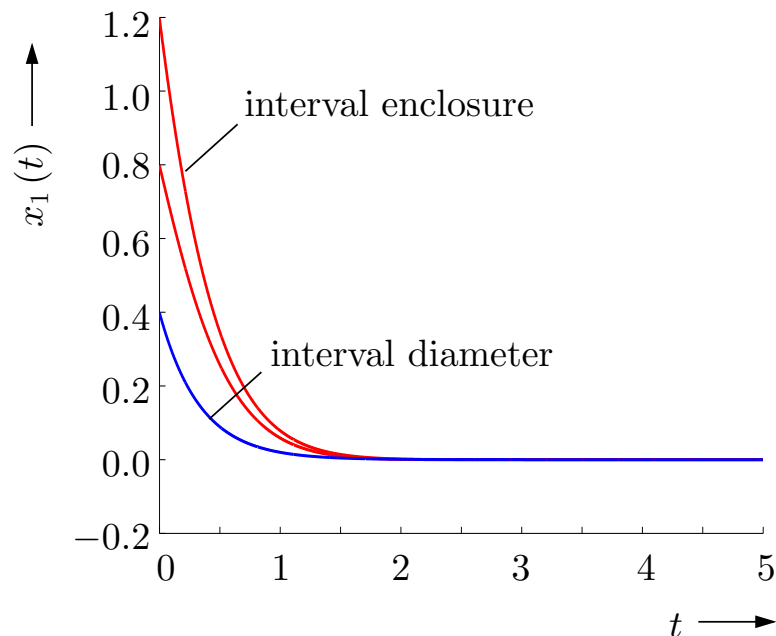

Example 1 (cont'd)

- Dynamic system model

$$\dot{\mathbf{z}}(t) = \tilde{\mathbf{A}}\mathbf{z}(t) \quad \text{with} \quad \tilde{\mathbf{A}} = \begin{bmatrix} \sigma_1 + j\omega_1 & 0 \\ 0 & \sigma_1 - j\omega_1 \end{bmatrix}, \quad \sigma_1 = -3, \quad \omega \in [0.95; 1.05]$$

- Initial conditions (midpoint radius form)

$$\mathbf{z}(0) \in \left[\left\langle \frac{1}{2}\sqrt{2} \cdot (1 - j), \frac{1}{10}\sqrt{2} \right\rangle, \left\langle \frac{1}{2}\sqrt{2} \cdot (1 + j), \frac{1}{10}\sqrt{2} \right\rangle \right]$$

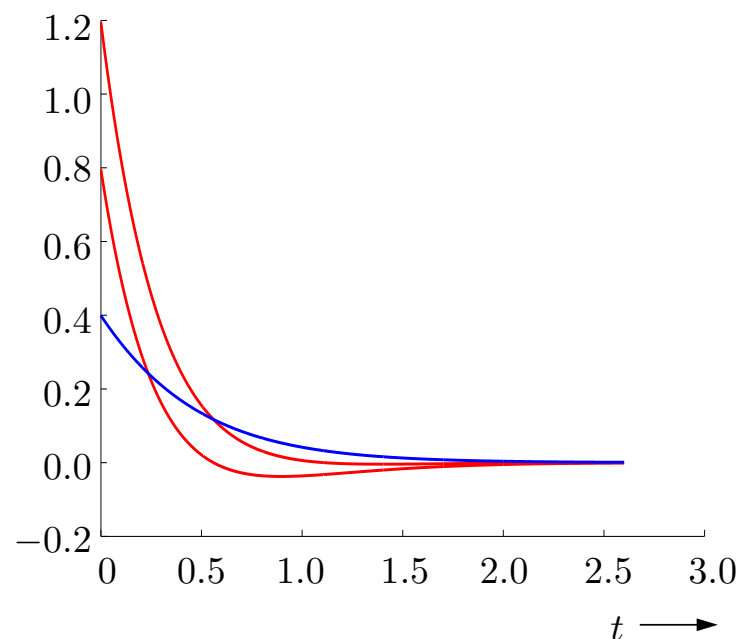
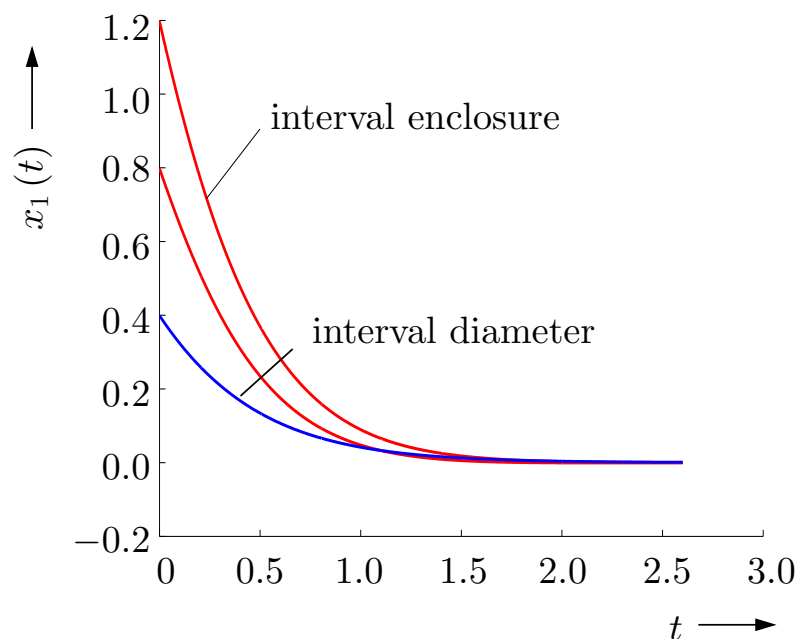

Example 1 (cont'd)

- Dynamic system model

$$\dot{\mathbf{x}}(t) = \mathbf{A}\mathbf{x}(t) + \begin{bmatrix} \sin(x_1(t)) \\ 0 \end{bmatrix} \quad \text{with} \quad \mathbf{A} = \begin{bmatrix} \sigma_1 & \omega_1 \\ -\omega_1 & \sigma_1 \end{bmatrix}, \quad \sigma_1 = -3, \quad \omega = 1$$

- Initial conditions $\mathbf{x}(0) = [1 \quad 1]^T$
- Transformation of the linear part into complex Jordan normal form

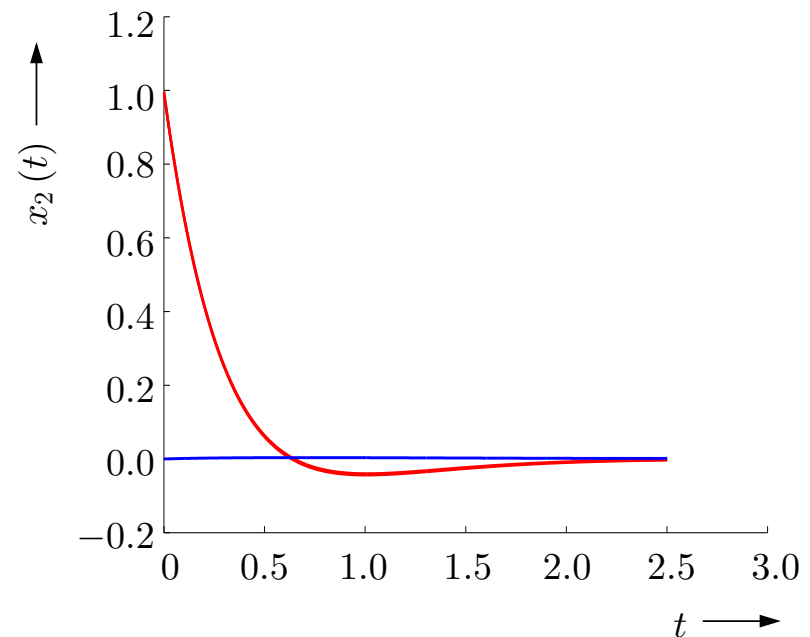
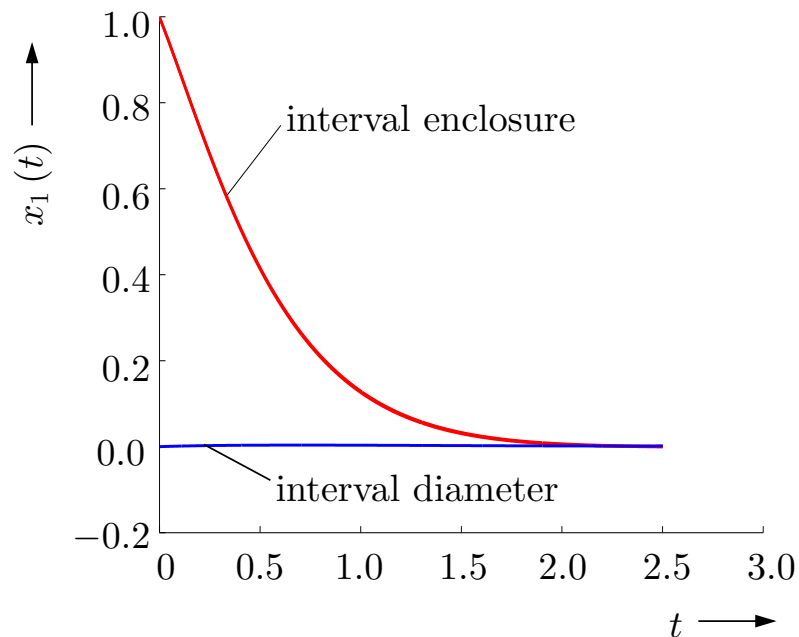

Example 2

- Dynamic system model ($\sigma_1 = -3, \omega_1 = 1, \sigma_2 = -6, \omega_2 = 2$)

$$\dot{\mathbf{x}}(t) = \mathbf{A}\mathbf{x}(t) \quad \text{with} \quad \mathbf{A} = \begin{bmatrix} \sigma_1 & \omega_1 & 1 & 0 \\ -\omega_1 & \sigma_1 & 0 & 1 \\ 0 & 0 & \sigma_2 & \omega_2 \\ 0 & 0 & -\omega_2 & \sigma_2 \end{bmatrix}$$

- Initial conditions $x_i(0) \in [0.9 ; 1.1], i = 1, \dots, 4$

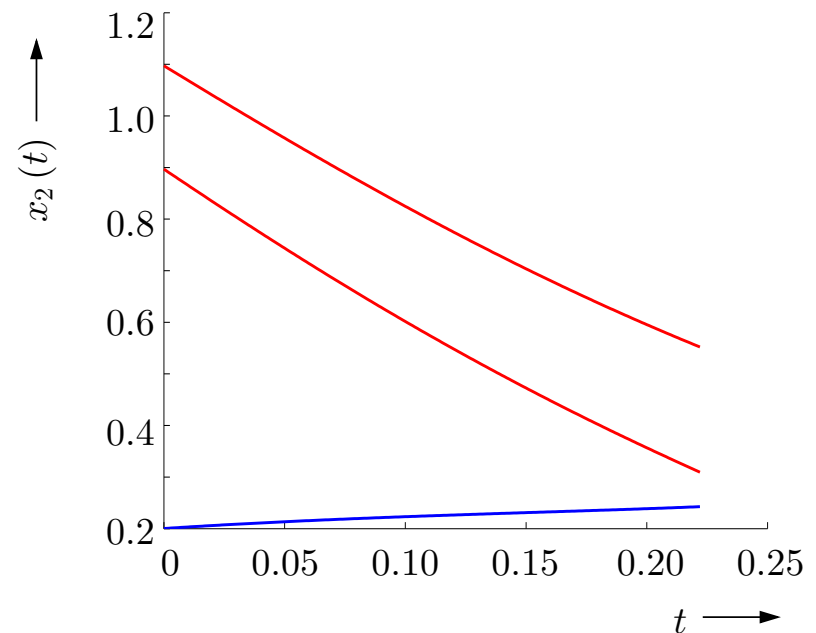
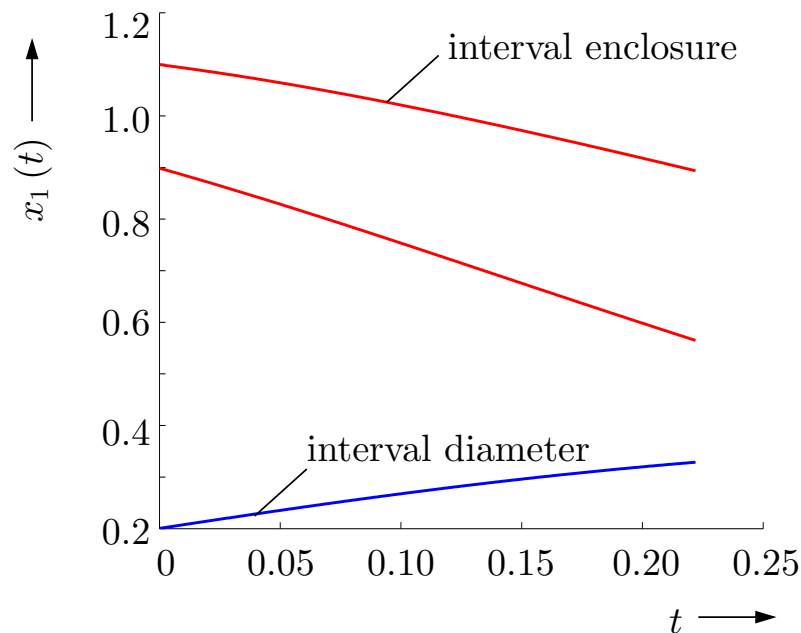

Example 2 (cont'd)

- Transformation into the complex Jordan normal form

$$\dot{\mathbf{z}}(t) = \tilde{\mathbf{A}}\mathbf{x}(t) \quad \text{with} \quad \tilde{\mathbf{A}} = \begin{bmatrix} \sigma_1 + j\omega_1 & 0 & 0 & 0 \\ 0 & \sigma_1 - j\omega_1 & 0 & 0 \\ 0 & 0 & \sigma_2 + j\omega_2 & 0 \\ 0 & 0 & 0 & \sigma_2 - j\omega_2 \end{bmatrix}$$

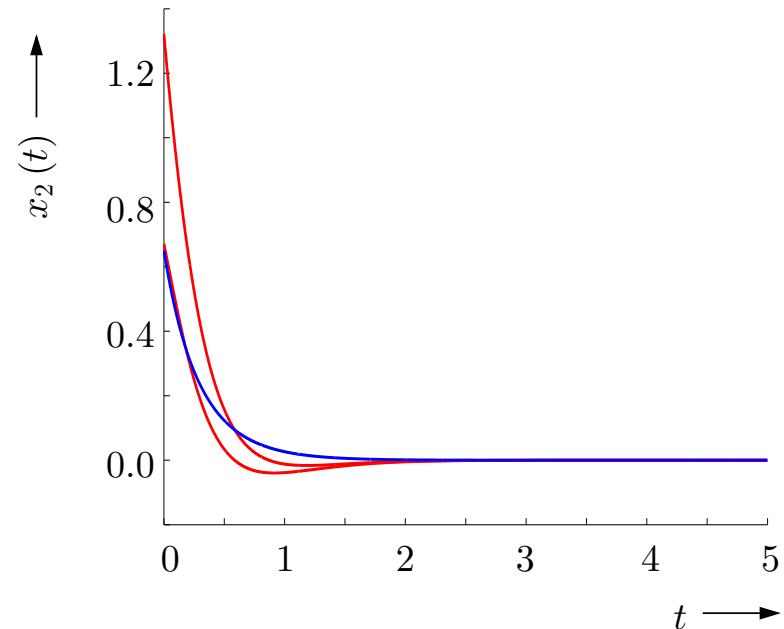
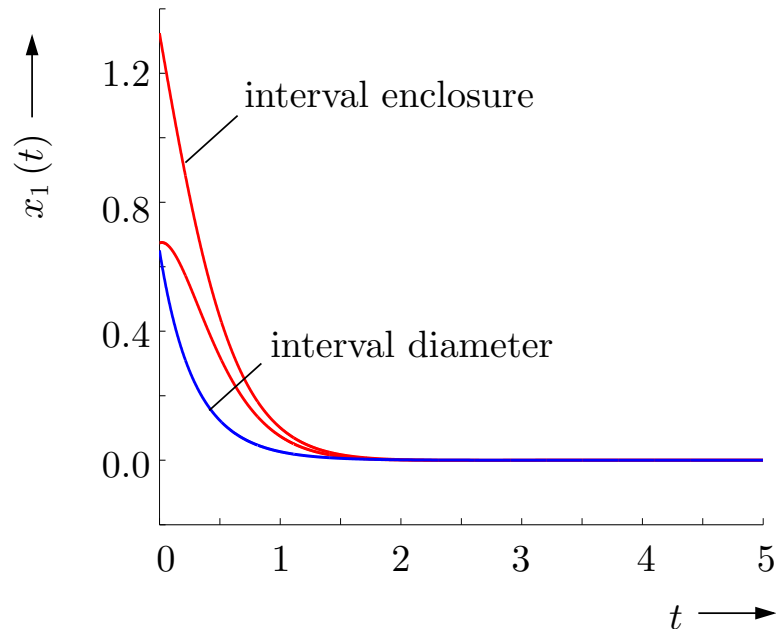

Example 3

- System with multiple eigenvalues

$$\dot{\mathbf{z}}(t) = \tilde{\mathbf{A}}\mathbf{x}(t) \quad \text{with} \quad \tilde{\mathbf{A}} = \begin{bmatrix} \sigma_1 + j\omega_1 & 1 & 0 & 0 \\ 0 & \sigma_1 + j\omega_1 & 0 & 0 \\ 0 & 0 & \sigma_1 - j\omega_1 & 1 \\ 0 & 0 & 0 & \sigma_1 - j\omega_1 \end{bmatrix}$$

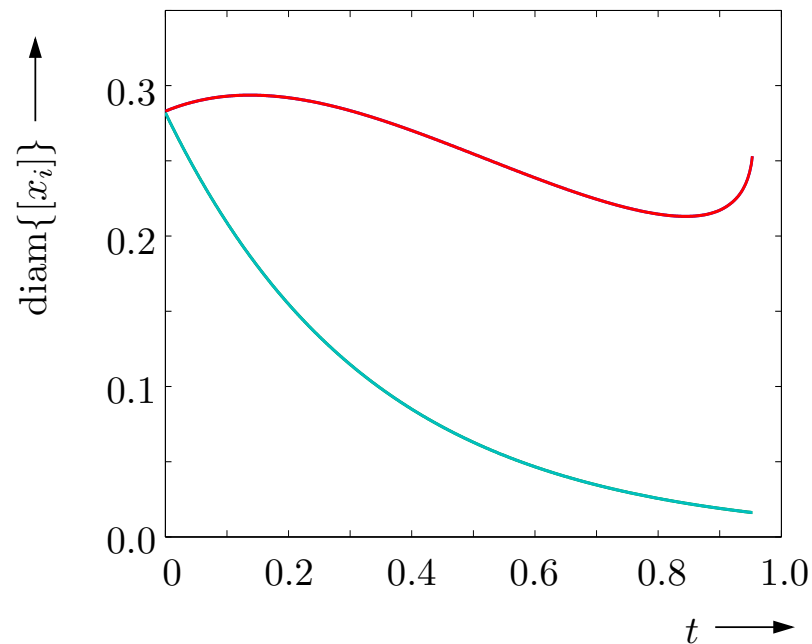

Application to VALENCIA-IVP for DAE Systems (1)

- Definition of systems of differential algebraic equations (DAEs)

$$\dot{\mathbf{x}}(t) = \mathbf{f}(\mathbf{x}(t), \mathbf{y}(t), t) \quad \text{with} \quad \mathbf{f} : D \mapsto \mathbb{R}^{n_x}$$

$$0 = \mathbf{g}(\mathbf{x}(t), \mathbf{y}(t), t) \quad \text{with} \quad \mathbf{g} : D \mapsto \mathbb{R}^{n_y}, D \subset \mathbb{R}^{n_x} \times \mathbb{R}^{x_y} \times \mathbb{R}^1$$

with **consistent initial conditions** $\mathbf{x}(0)$ and $\mathbf{y}(0)$

- General case: implicit ODE/ DAE systems

Application to VALENCIA-IVP for DAE Systems (2)

$$\begin{aligned}
 \dot{\mathbf{x}}_{app}([0; T]) + [\dot{\mathbf{R}}_x([0; T])] &= \\
 \mathbf{f} \left(\mathbf{x}_{app}([0; T]) + [\mathbf{R}_x(0)] + [0; T] \cdot [\dot{\mathbf{R}}_x([0; T])], \right. \\
 \left. \mathbf{y}_{app}([0; T]) + [\mathbf{R}_y(0)] + [0; T] \cdot [\dot{\mathbf{R}}_y([0; T])], [0; T] \right) \\
 \hline
 0 = \mathbf{g} \left(\mathbf{x}_{app}([0; T]) + [\mathbf{R}_x(0)] + [0; T] \cdot [\dot{\mathbf{R}}_x([0; T])], \right. \\
 \left. \mathbf{y}_{app}([0; T]) + [\mathbf{R}_y(0)] + [0; T] \cdot [\dot{\mathbf{R}}_y([0; T])], [0; T] \right)
 \end{aligned}$$

Conclusions and Outlook on Future Research

- Exponential enclosure techniques for linear systems
- Transformation into real Jordan normal form
- Transformation into complex Jordan normal form

Conclusions and Outlook on Future Research

- Exponential enclosure techniques for linear systems
- Transformation into real Jordan normal form
- Transformation into complex Jordan normal form
- Full implementation as a further option in VALENCIA-IVP
- Application to state prediction also for nonlinear systems
- Computation of guaranteed state intervals in order to embed nonlinear dynamics in quasi-linear system models with polytopic uncertainty
- Design of guaranteed stabilizing control laws by means of linear matrix inequalities (LMIs)

Vielen Dank für Ihre Aufmerksamkeit!

Thank you for your attention!

Merci beaucoup pour votre attention!

Спасибо за Ваше внимание!

Dziękuję bardzo za uwagę!

¡muchas gracias por su atención!

Grazie mille per la vostra attenzione!